

 **BraunAbility**
Life is a Moving Experience

LIFE IS A MOVING EXPERIENCE®

Get out there.



FORD EXPLORER

MIXVTM



"I CAN. I WILL."

"We only have a short window of life to enjoy.
You've gotta do what you want to do."

– JESSE BILLAUER



A New Force of Freedom

It's finally here—the freedom of an accessible van with the style and swag of an SUV. Built on the Ford Explorer, the BraunAbility MXV™ blends innovative design with the trusted quality you expect from BraunAbility. It's tough. It's original. It's a new force of mobility freedom—get out there!

In 1996, 17-year-old Jesse Billauer drove out to the beach where the waves were perfect swells. At the time he was among the top 100 junior surfers in the world, on his way to becoming a professional. The ocean was beautiful and calm, until a large wave knocked him onto a sandbar, instantly paralyzing him.

When Billauer learned he'd never walk again, he began to wonder how he'd survive without the sport he loved. Three years later, Billauer created a board equipped with a bar to hold on to, allowing paralyzed individuals like him get back to surfing. He took his passion a step further, starting Life Rolls On Foundation, an organization dedicated to introducing wheelchair users to skating and surfing. Now Billauer and his LRO volunteers are able to share their passion with nearly one thousand wheelchair athletes every year.

Configured to fit you.



Minivan space. SUV swag.



Transfer seat capable!



A wheelchair user can ride in the middle row depending on the size of the wheelchair.



Removable passenger seat allows a wheelchair user to ride in the front passenger position.



Removable driver's seat allows a wheelchair user to drive from a wheelchair.

The BraunAbility MXV™ holds six patent-pending features, including a glide-out door operation and a space-saving sliding shifter. BraunAbility's dependable infloor technology maximizes interior space, and removable driver and passenger seating offers flexibility for power and manual wheelchairs. Any way you want it, the MXV has room for you and all you want to do.



Space-saving innovation.



Seat Design

Maximized space with cantilevered seat base design (patent pending).



Sliding Shifter

Sliding shifter can slide side-to-side for extra space for a driver or passenger (patent pending).



Infloor Technology

Proven BraunAbility infloor technology with lighted ramp for added convenience.

Not your average wheelchair vehicle.

Removable Seats

Removable seating for added floor plan flexibility.



Towing Package

Optional tow package with removable cover.



Gliding Door Operation

Innovative door operation glides compactly against vehicle (patent pending).



Nerf Bar

Rugged nerf bars come standard.

The choice is yours.

COLOR

Outside the lines.



BLUE JEANS



RUBY RED



WHITE PLATINUM



SHADOW BLACK



INGOT SILVER



OXFORD WHITE



MAGNETIC METALLIC

Additional Features

- » Integrated key fob
- » Removable cup holder
- » Multiple media ports
- » Spring-loaded backseat footrest
- » Door/ramp operation buttons in multiple locations
- » Ramp and kneel on/off switch

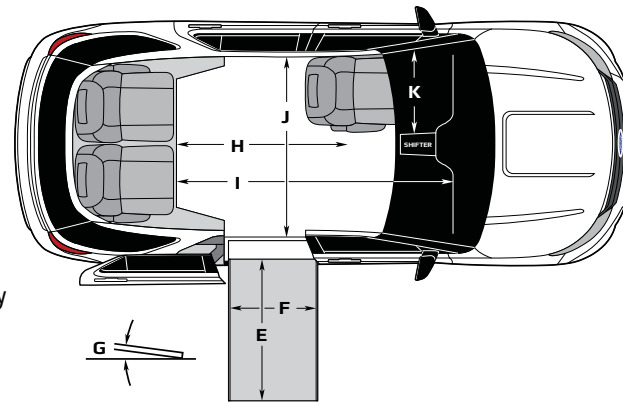
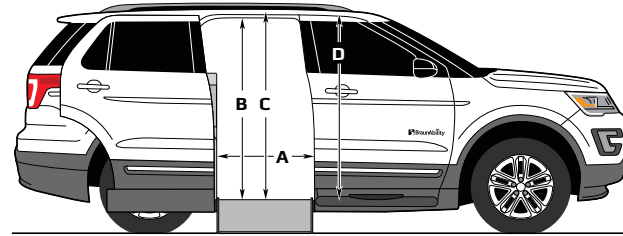

An Iconic Foundation

Original. Tough. All-American. BraunAbility selected America's first and favorite SUV, the Ford Explorer, as the base of our first wheelchair accessible SUV.

Door opening usable width	A	28-1/2"
Door opening usable height	B	55"
Interior height (center of vehicle)	C	58"
Interior height (driver/passenger position)	D	59"
Ramp length	E	52"
Ramp width (usable clear opening)	F	28"
Ramp angle (kneeled)	G	9°
Interior floor length (behind front seats)	H	55"
Overall interior floor lengths (flat area)	I	85"
Interior width at B pillars	J	59-1/2"
Driver/passenger position width (between sliding shifter)	K	24" / 27"



Safety Tested

Like all BraunAbility accessible vehicles, the MXV™ is engineered to the highest standards. We've invested in industry-leading safety testing to meet or exceed government safety standards.

"I CAN. I WILL."

"I'm never going to give up. Racing is my life."

– MICHAEL JOHNSON



Michael Johnson is the first and only paralyzed licensed INDYCAR driver to compete in the developmental ladder program, Road to Indy. Now, having switched to SportsCar racing, Johnson plans to compete in the 2016 IMSA Continental Tire SportsCar Challenge in the Street Turner Class.

Johnson was severely injured at the age of 12 when he lost control of his motorcycle during a race. He was then paralyzed from the mid-chest area down. He now races with a car equipped with hand controls of his and his father's invention. Physical fitness is important to any driver, but particularly for Johnson, who uses only his upper body during the whole two-hour-long race.

He's a paralyzed athlete, but always an athlete first.

Making the world accessible.



About Our Founder

Ralph Braun built our company based on his own need for mobility. He passed away in 2013 but has left a permanent legacy that still guides BraunAbility today.



Other BraunAbility Products

BraunAbility offers the widest selection and lineup of mobility vehicles for both the consumer and the commercial markets.



Global Awareness

With an employee and dealer base stretching across the globe, we have a clear mobility mission—to make the world accessible!



Affordable mobility has never been easier—ask your dealer about low rates through BraunAbility Finance!

More online:
braunability.com



800.THE.LIFT

800.843.5438

braunability.com



©2016 BraunAbility. All rights reserved. All illustrations, descriptions and specifications in this brochure are based on the latest product information at the time of publication. BraunAbility reserves the right to make changes at any time without notice. #501343